

**Index Cutting Machine:
 Dies form 01-06**

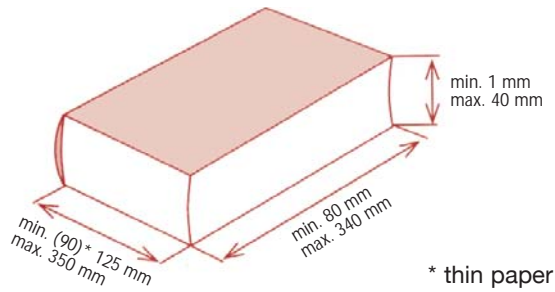

* thin paper

01

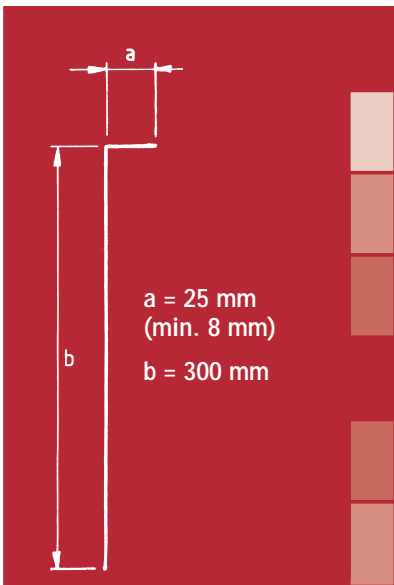

02

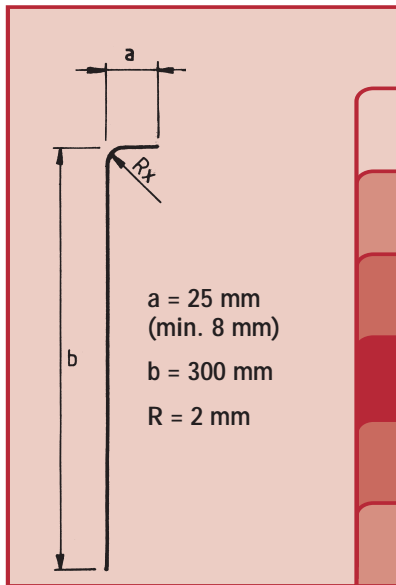

03

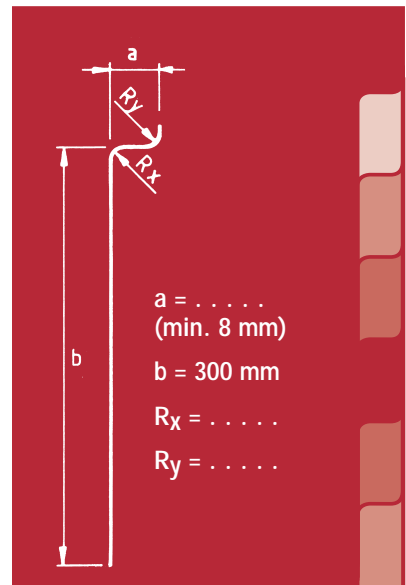

04

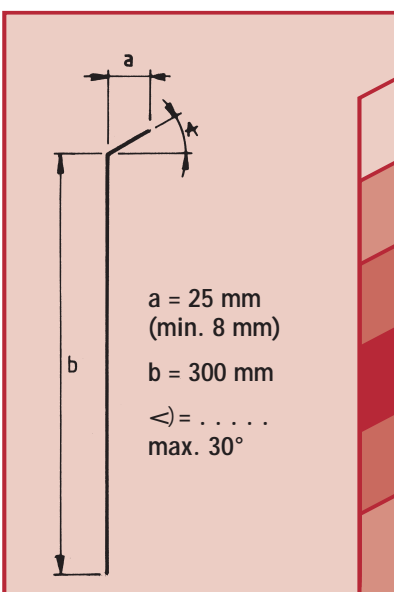

05

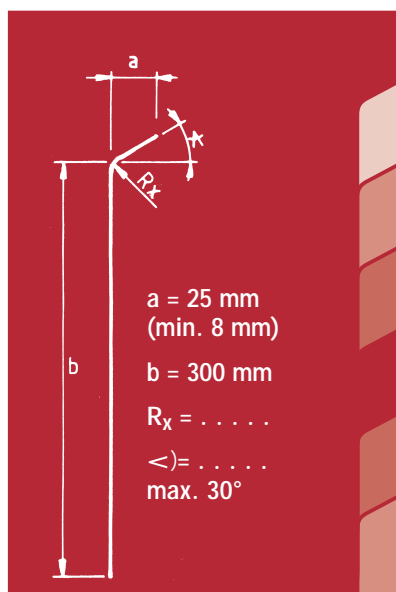

06

